



SAIL MEASUREMENTS FOR:

Name		Name of Measurer	Date Measured
Address		Day Phone:	
City, State, Zip		E-Mail:	
Manufacturer	Model	Year	
Boat Name	Sail Number	Number	Color

The following measurements can be found on your boat's sail plan, rating certificate or in its specifications. If your boat has a rating certificate, please send us a photocopy.

I: _____ J: _____ LL: _____ P: _____ E: _____ LP: _____

Measurement Notes:

- DO NOT** measure your old sails. Sails stretch and distort over the years. However, do include any unique details that pertain to the fit of your old sails to your boat, i.e. corner hardware or spreader patch position. The blank space on the form is for notes.
- Make sure to use a steel or fiberglass reinforced measuring tape. Attach a separate "pull down" or retrieving line on your halyard before hoisting.
Do not rely on the measuring tape to pull the halyard down.

CIRCLE WHICHEVER APPLIES

BOAT IS: Full Race Race/Cruise Cruise

HANDICAP RULES RACED UNDER: One-Design
IRC PHRF MORC _____

BOAT'S RIG IS: Masthead Fractional Unstayed

RIG HAS: Running Backstays Babystay

BACKSTAY TENSION SYSTEM IS: Turnbuckle
Block & Tackle Hydraulic

STEP 1: MAIN SAIL MEASUREMENTS

Max. Luff

Check if measured to the band

Main Sail Maximum Luff is measured by pulling the main halyard up as high as possible and then measuring to the top of the gooseneck. If your mast has a black band at the top, raise the tape until it is just at the lower edge of the band. You'll probably have to site the position of the tape from off the boat. If you measured to the black band, check the box.

Straight Line Leech

Next, while the halyard is still all the way up, measure to the bearing point on the outhaul car when it is at the same angle as it is when sailing.

Mast Bend

Finally, measure the amount of mast bend by lowering the tape measure and holding the halyard tight at the intersection of the boom and the mast. Site up and record the maximum number of inches between the mast and the halyard. To help make your judgement, measure the fore-and-aft dimension of the mast and use the column width as a reference. Make sure that the backstay is tensioned before making the measurement.

Max. Foot

Check if measured to the band

The maximum foot length of the main is measured along the boom, between the aft face of the mast and inner end of the black band at the end of the boom. If there is no measurement band, measure to the clew car pin when the car is at it's maximum extended position.

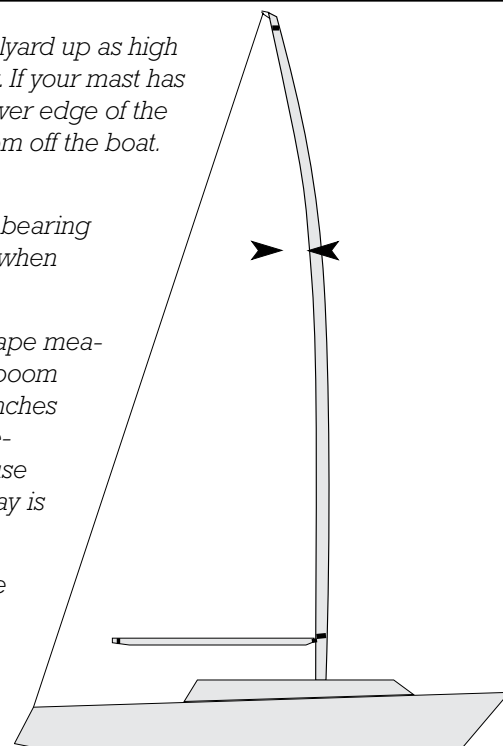



MORE MAINSAIL MEASUREMENTS

P: _____ E: _____

Fill in "W,X,Y,Z," if your outhaul is on a track, or just "Y" & "Z" if your out haul is just a shackle.

W	Height of bearing point on outhaul car from the top of the boom.
X	Distance from black band to loosest outhaul setting.
Y	Distance from black band to end of bolt rope groove or end of the boom track.
Z	The jaw width of the shackle or tack attachment mechanism

A	Aft face of mast to bearing point of tack fitting.
B	Top of boom to bearing point of tack fitting.
C	Aft face of mast to bearing point of reef hook.
D	Top of boom to bearing point of reef hook.
E	Aft face of mast to end of groove or track.
F	Top of boom to luff groove exit or slide stop—whichever is higher.

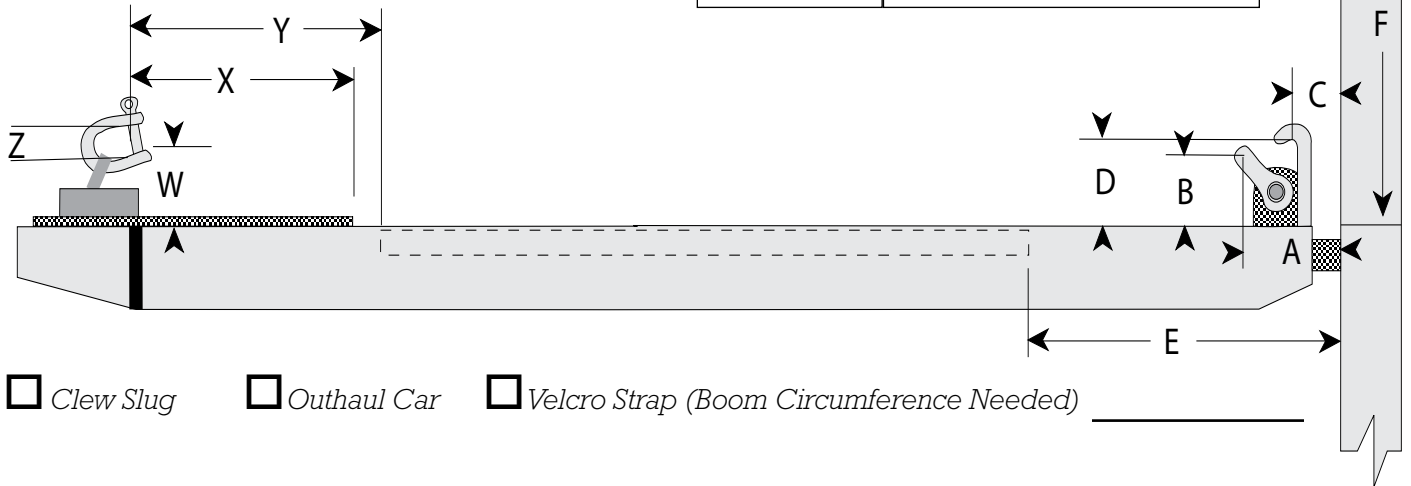

NOTES

FOOT AND LUFF SLIDES

<p>Slug or Bolt Rope</p> <p>Circle one Slug or Rope Diameter</p> <p>1/4" 5/16" 3/8" 7/16" 1/2"</p> <p>Groove Width: _____</p> <p><input type="checkbox"/> Mast <input type="checkbox"/> Boom</p>	<p>External Slide</p> <p>Track Width Circle one</p> <p>5/8" 7/8" 1"</p> <p><input type="checkbox"/> Mast <input type="checkbox"/> Boom</p>
--	--

INTERNAL SLIDE

Slide Width:
Circle one

5/8"
3/4"
7/8"
15/16"

A: _____

B: _____

C: _____

Mast Boom



HEADSAIL MEASUREMENTS

I: _____ J: _____ **Roller Furling Cover** Port / Starboard Side (circle one)

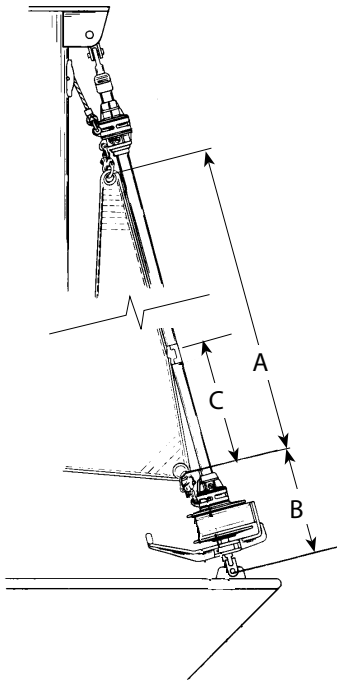

Roller Furlers

When furling system installed, measure "A"—the maximum luff. Attach tape measure to lower shackle of the halyard swivel. Next, raise swivel as high as possible and measure to the tack shackle on the top of furling unit's drum.

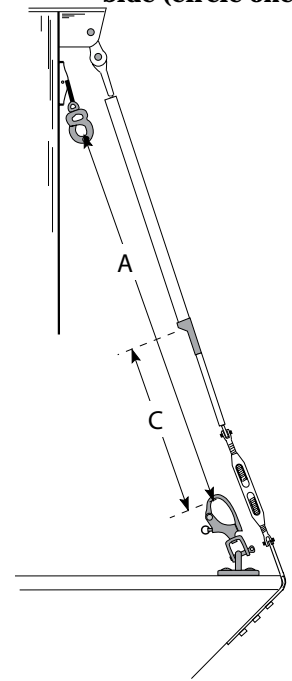
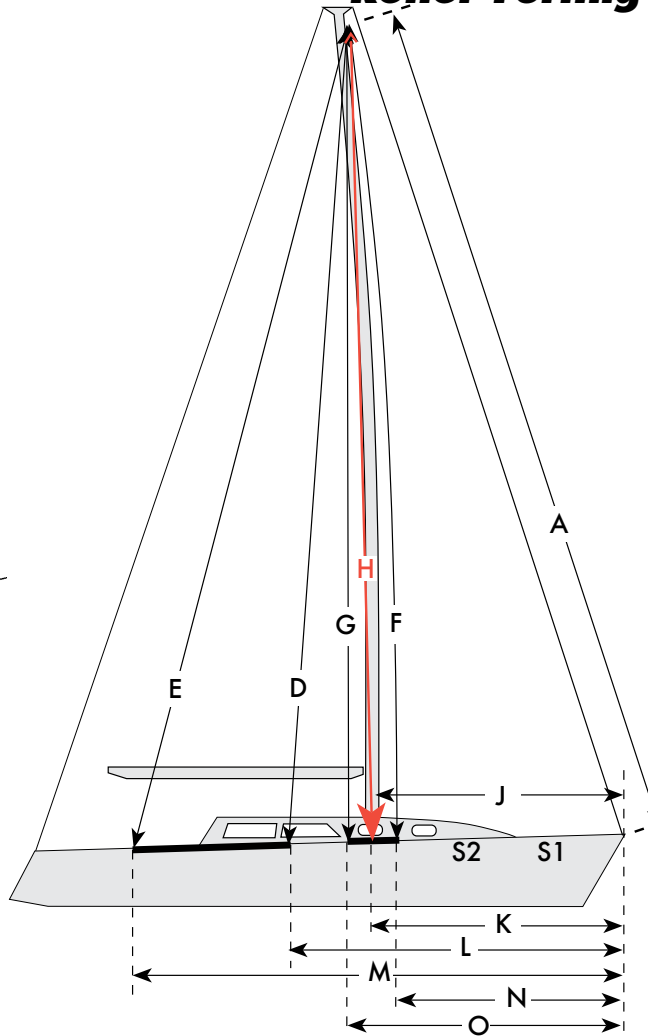

Non-Roller Furling

Measure the max luff by attaching a tape measure to the GENOA halyard shackle and raise the halyard as high as it will go. Measure to the bearing point on the tack fitting.

TENSION THE BACKSTAY TO AVERAGE UPWIND SETTING BEFORE TAKING MEASUREMENTS.

A:	B:	A: Maximum Luff
C:		B: Forestay attachment pin to tack shackle on the roller furling drum.
		C: Bearing point of tack shackle to the feeder in the headstay foil.
If using roller furler, raise swivel as high as it will go, otherwise raise genoa halyard and take the following measurements.		
D:	E:	D: Forward end of the genoa track. Make sure tape passes around the shrouds as if it were the leech of a sail. Pull tight when measuring.
F:	G:	E: Aft end of the genoa track; use above procedure.
H:		F: Forward end of No.3 track
		G: Aft end of No.3 track
		H: To the chainplate.
Take the following measurements along the deck from the bearing point on the tack fitting .		
J:	K:	J: To the front of the mast
L:	M:	K: To the base of the shrouds.
N:	O:	L: To the bearing point of the genoa car at the forward end of the genoa track
S1:	S2:	M: To the bearing point of the genoa car at the aft end of the genoa track
S3:	S4:	N: To the bearing point of the genoa car at the forward end of the No. 3 track (if separate).
S5:	SH:	O: To the bearing point of the genoa car at the aft end of the No. 3 track (if separate).
		S1: To all the stanchions in front of the shrouds.
		SH: Stanchion Height.

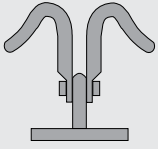
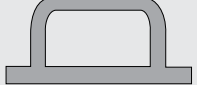
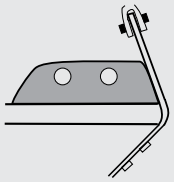
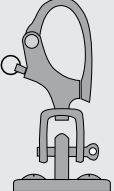
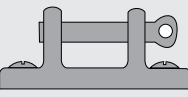

FORESTAY & TACK FITTING DETAILS

<input type="checkbox"/> HORN 	<input type="checkbox"/> BAIL 	<input type="checkbox"/> SINGLE PLATE 	DRAW OTHER
<input type="checkbox"/> SNAP SHACKLE 	<input type="checkbox"/> DOUBLE PLATE 	Tack Set Up & Set Back <p>From the bearing point of the tack fitting to the deck. the deck.</p> <input type="text"/>	
		<p>Measure from bearing point of the tack fitting to the forestay.</p> <input type="text"/>	

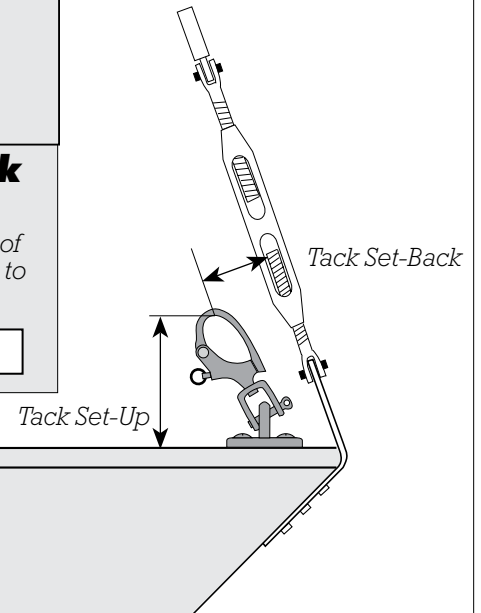

Headstay System

Hanks or Snaps
 Wire or Rod diameter:

Foil Headstay
 Manufacturer:
 Model/Size:
 Luff Tape Size:

Roller Furling:
 Manufacturer:
 Model/Size:
 Luff Tape Size:
 Side for UV Cover:

With this information your UK-Halsey Sailmaker will make sails that are custom designed for your boat. If your boat has rigging, spars or any hardware different than noted, please use the white space to tell us how it differs. Feel free to attach pictures and drawings on separate sheets of paper if needed. **For instance, if your spars don't have black measurement bands, make sure to tell us where you measured to!**

FINALLY, A PICTURE IS WORTH 1000 WORDS, PLEASE FEEL FREE TO INCLUDE PHOTOS OF YOUR TACK, CLEW, REEFING, AND FURLING GEAR.



MEASURING FOR SPREADER PATCHES

A	<i>From genoa halyard all the way up to deck at chainplate passing around top spreader tip.</i>
B	<i>From upper spreader tip to the deck at the chainplate</i>
C	<i>From upper spreader tip to the bearing point of the genoa tack fitting.</i>
D	<i>From second spreader down's tip to the deck at the chainplate</i>
E	<i>From second spreader tip to the bearing point of the genoa tack fitting.</i>
F	<i>From third spreader down's tip to the deck at the chainplate</i>
G	<i>From third spreader tip to the bearing point of the genoa tack fitting.</i>

Red line indicates path of tape measure when measuring for Box A.

